



# PRODUCT SPECIFICATION

**Model No.: FYL-3014URC**

Descriptions:
<ul style="list-style-type: none"> <li>■ Dice material: AlGaInP.</li> <li>■ Emitting Color: Super bright Red.</li> <li>■ Device Outline: Φ3mm round type.</li> <li>■ Lens Type: Water clear.</li> </ul>



CUSTOMER APPROVED SIGNATURES	APPROVED BY	SALES BY	PREPARED BY
			

**NINGBO FORYARD OPTOELECTRONICS CO.,LTD**

**Add:**No. 666 Jinhua Road, Hi-tech Park, Ningbo, Zhejiang, China

**Zip:**315103

**Tel:** 0086-574-87933652 87927870 87922206

**Fax:** 0086-574-87927917

**E-mail:**Sales@foryard.com (General)

**Http://www.foryard.com**

**Model No.: FYL-3014URC**

■ ⑤ Features

- 1.Low power consumption.
- 2.High efficiency.
- 3.General purpose leads.
- 4.High intensity.
- 5.RoHs compliant.

■ Package configuration

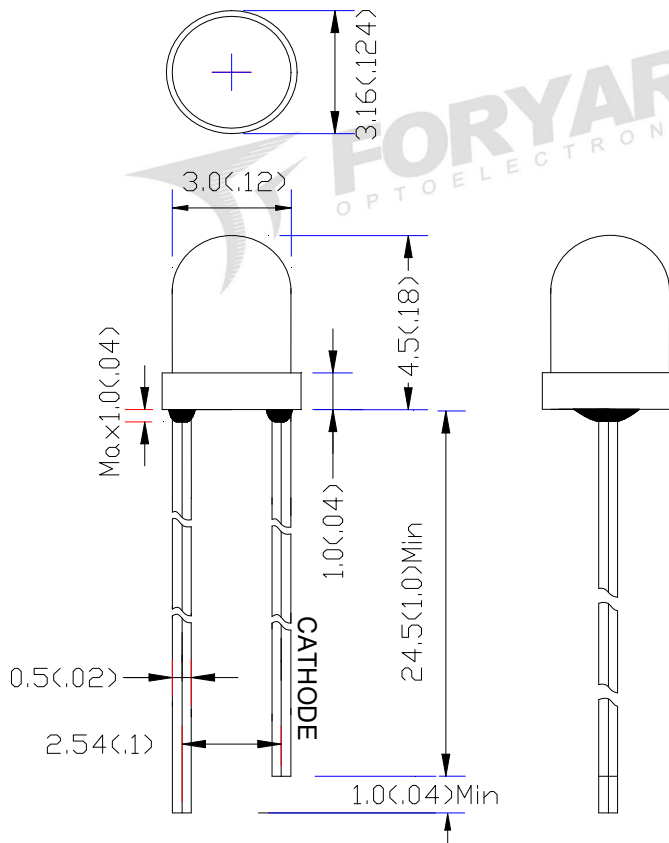

Notes:

1. All dimensions are millimeters (inches)
2. Tolerance is  $\pm 0.25\text{mm}$  (.010") unless otherwise noted.
3. The specifications, characteristics and technical data described in the datasheet are subject to change without prior notice.

**Model No.: FYL-3014URC**

**Absolute Maximun Ratings(Ta=25° C)**

Parameter	MAX.	Unit
Power Dissipation	75	mW
Peak Forward Current (1/10 Duty Cycle, 0.1ms Pulse Width)	100	mA
Continuous Forward Current	30	mA
Derating Linear From 50°C	0.4	mA/°C
Reverse Voltage	5	V
Operating Temperature Range	-40°C to +85°C	
Storage Temperature Range	-40°C to +100°C	
Lead Soldering Temperature[4mm(.157") From Body]	260°C for 5 Seconds	

**Typical Electrical &Optical Charcteristics(Ta=25°C)**

Parameter	Symbol	Min.	Typ.	Max.	Unit	Test Condition
Luminous Intensity	$I_v$	350	700	-	mcd	IF=20mA
Viewing Angle	$2\theta_{1/2}$		80		Deg	
Peak Emission Wavelength	$\lambda_p$	-	630	-	nm	
Dominant Wavelength	$\lambda_d$	618	625	630	nm	
Spectral Line Half-Width	$\Delta\lambda$	-	15	-	nm	
Forward Voltage	$V_F$	1.7	2	2.3	V	
Reverse Current	$I_R$			10	$\mu A$	VR=5V

Note:

- 1.Luminous Intensity is based on the Foryard standards.
- 2.Pay attention about static for InGaN

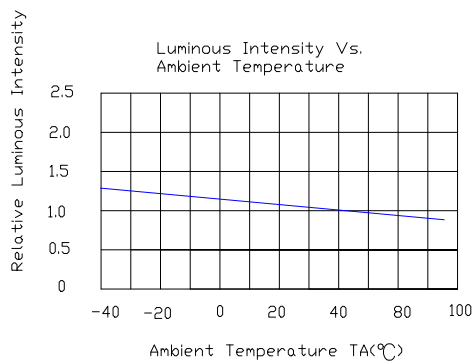
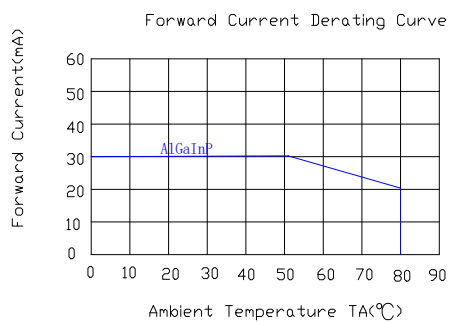
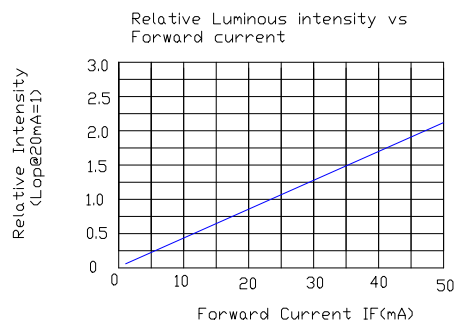
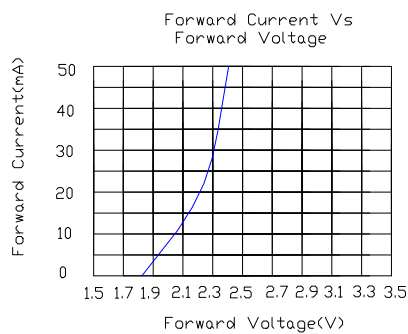
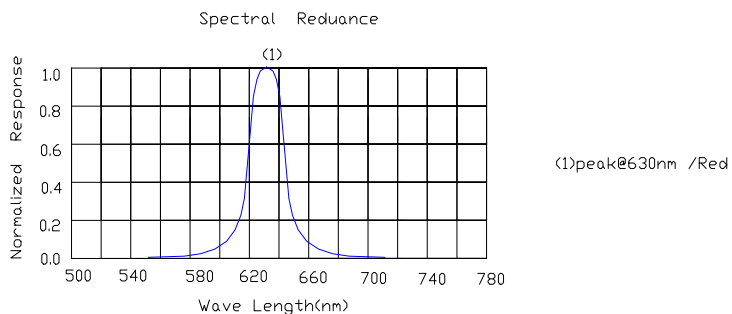
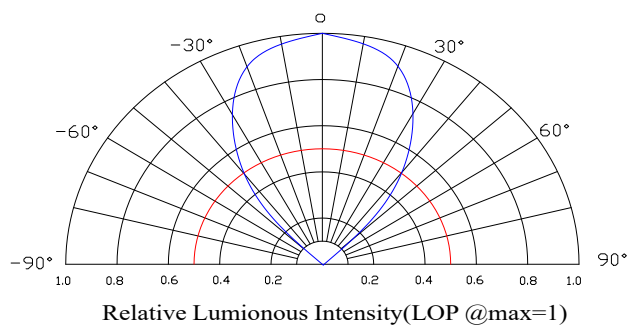
**Model No.: FYL-3014URC**
**Typical Electrical/Optical Characteristics Curves(Ta=25°C Unless Otherwise Noted)**

**Radiation pattern.**

Model No.: FYL-3014URC

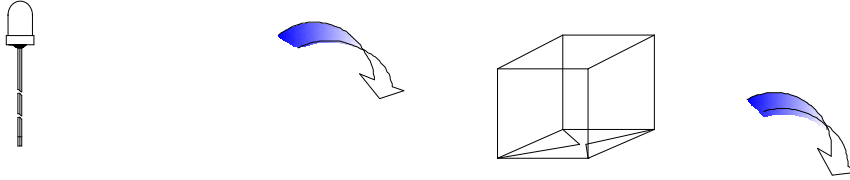
⑤ ■ LAMP PACKING.

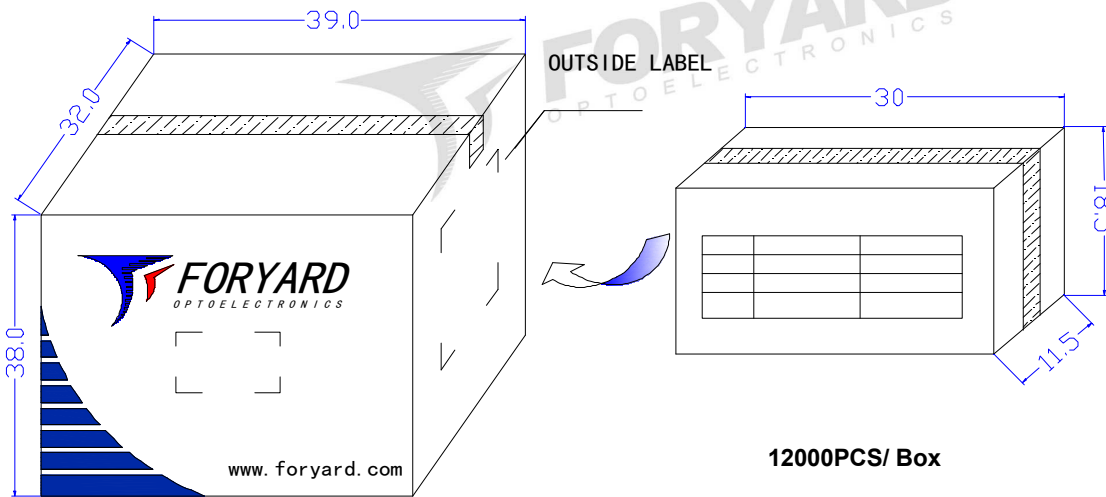
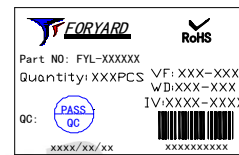

3mm 1000PCS/Polybag



72000PCS/ Carton



OUTSIDE LABEL