

未注公差/General tolerances(mm)											0.1/10		
0	>3	>6	>10	>18	>30	>50	>80	>120	>180	>250		>315	>400
~3	~6	~10	~18	~30	~50	~80	~120	~180	~250	~315	~400	~500	~2.50
±0.12	±0.18	±0.22	±0.26	±0.31	±0.37	±0.57	±0.80	±0.93	±1.05	±1.15	±1.60	±2.20	±2.50

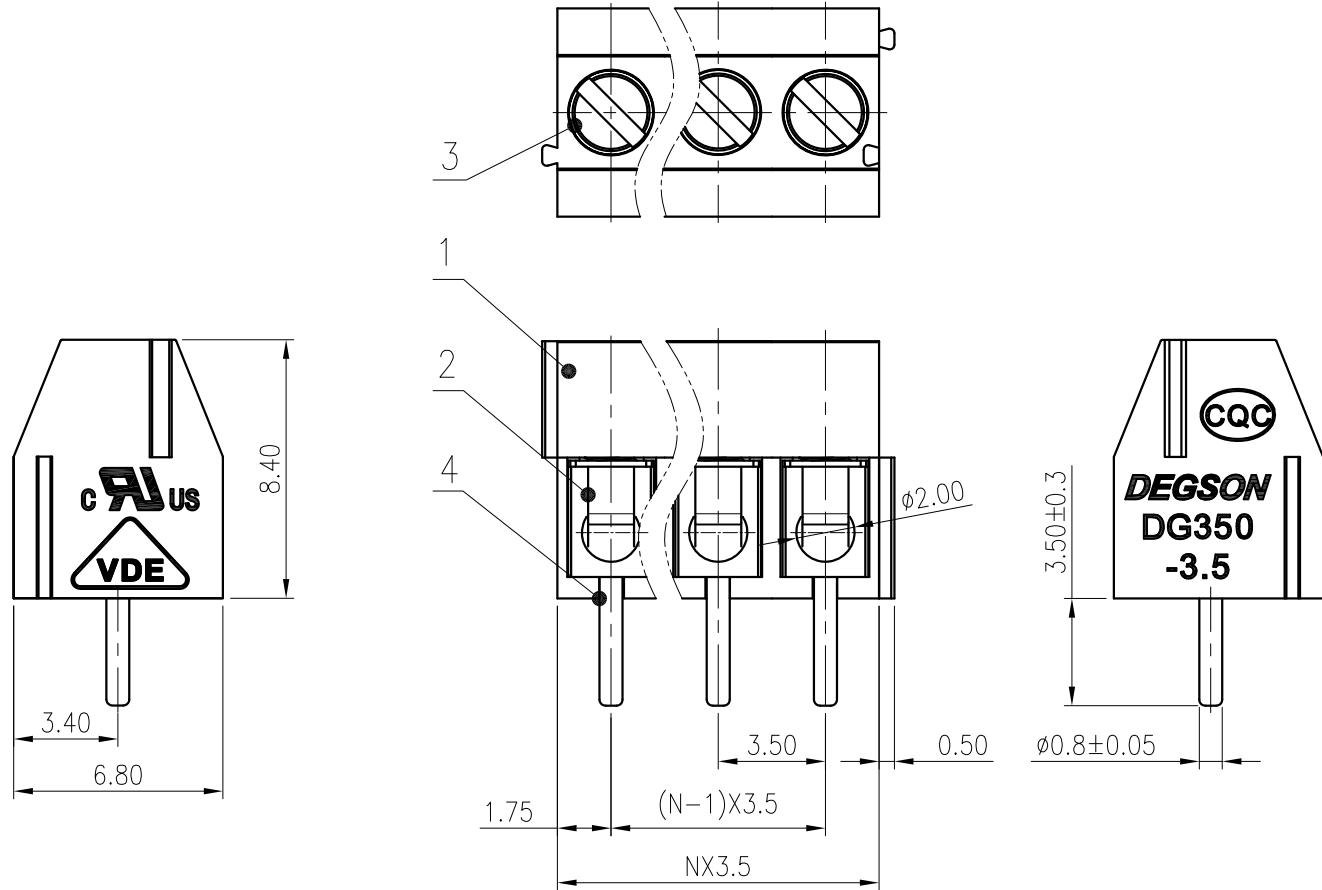

ITEM	NAME OF PART	MATERIAL	NOTES
4	Pin header	Copper alloy	M2/Sn plated
3	Screw	Steel	M2/Zn plated
2	Spring	Stainless steel	/
1	Housing	PA66	UL94V-0
UL 标准/UL Standard:		B	C
额定电压/电流/Rated Voltage(V)/Current(A)		300/7	/
EC 标准/IEC Standard:			
过压类别/Overvoltage Category/污染等级/Pollution Degree		III/3	III/2
额定电压/电流/Rated Voltage(V)/Current(A)		/	130/10
工频耐压/Withstanding voltage(V/1Min)		AC1250	
螺丝扭矩/Torque Tightening(N·m/Lb.in)		M2, 0.20/1.77	
线径范围(硬线和软线)/Wire Range(rigid and flexible)(mm ² /AWG)		0.5~1.0/24~18	
间距/Pitch(mm)/线数范围/Poles		3.5/N=02~24P	
剥线长度/Stripping length(mm)		5	
使用温度范围/Operating temperature(°C)		-40~+105	
符合RoHS环保要求/Conform to RoHS		Yes	

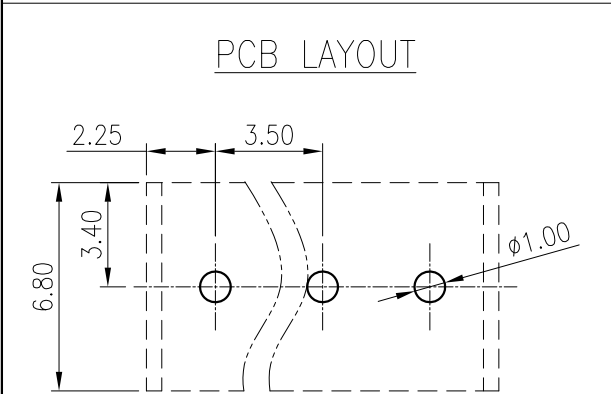

REV	ECN	DESCRIPTION	DRFT	DATE

MATERIAL:		SURFACE:	
MAT NO.:	/	宁波高松电子有限公司 NINGBO DEGSON ELECTRICAL CO., LTD	
STATUS:	/		
APPD: Lan ChH	2020.05.20	NAME: DG350-3.5-XXP-1Y-00A(H)	
CHKD: Yu JZh	2020.05.20	DRAWING NO.: DG350-3.5-C01	
DRFT: Song	2015.12.11	REV	T1
SIZE: A4	mm (inch)	TYPE: CUSTOMER DRAWING	SCALE: 4:1 SHEET 1/1