



## ELP18X1CS

Constant Current Power Supply

350mA / 30~60VDC / 9~18x1W LED / IP65



### I. Technical data

GENERAL	
Input voltage	220~240VAC
Input frequency	50/60Hz
Input current	0,13A Max.
Output voltage	30~60VDC
Output current	350mA
Load range	9~18x1W LED
Output connection	Cable connection; length max. 2 meter
Power factor	>0,9
Efficiency	>83%
No load losses	<0,3W
Environment temperature	-20°C~+45°C
Surface temperature	75°C max.
Protection class	IP65
MTBF	≥ 50000 hours (@ 25°C full load)
PROTECTION	
Isolation class	Class II, SELV
Short circuit protection	Resettable after fault removed
Over load protection	Resettable after fault removed
Over temperature protection	Resettable after temperature descending acc. IEC 61347-1 appendix C
Electric strength	IN-OUT / IN-FG: 3750VAC/5mA/1 min; OUT-FG: 500VAC/5mA/1 min;
Insulation resistor	≥ 4MΩ
STANDARD	
LVD	EN61347-1, EN61347-2-13
EMC	EN55015, EN61547, EN61000-3-2, EN61000-3-3
Approvals	CE, Intertek Semko
RoHS compatible	Yes



## FOR APPROVAL

### 承认书

客户 / CUSTOMER :	
产品名称 / TYPE : LED 电源 / LED Power Supply	
客户编号 / CUSTOMER NO. :	
产品型号 / MODEL : ELP18X1CS	
产品安装方式 / INSTALLATION : 内置式 / Built-in	
绝缘等级 / INSULATION CLASS: Class II, SELV	
防护等级 / PROTECTION GRADE : IP65	
RoHS : 符合 RoHS 要求 Comply with RoHS requirement	
编制 / DESIGN :	石从怀
批准 / APPROVAL :	熊川高
客户认可回签(章) AUTHORIZED SIGNATURE & COMPANY SEAL	

## EAGLERISE ELECTRIC & ELECTRONIC ( Foshan ) CO., LTD.

Add: Guicheng Sci-Tech Industrial Park, Jianping Road, Nanhai District, Foshan City, Guangdong Province, P.R. China

Tel: (0757) 86256632 86256772

Fax: (0757) 86256788

## 1. 输入特性/ INPUT CHARACTERISTIC

测试点 / TEST POINT	参数名称 / PARAMETER	技术指标 / TECHNIC GUIDELINE
1.1	输入电压 INPUT VOLTAGE	220-240VAC
1.2	输入频率 INPUT FREQUENCY	50/60Hz
1.3	输入电流 INPUT CURRENT	0.13A
1.4	功率因数 POWER FACTOR:	>0.9
1.5	空载功耗 NO LOAD POWER CONSUMPTION	<0.3W
1.6	输入线 INPUT WIRE	1990 20# 150mm

## 2. 输出特性/ OUTPUT CHARACTERISTIC

2.1	输出电流 OUTPUT CURRENT	315-375mA (30-62VDC) (Rated: 350mA)
2.2	输出空载电压 OUTPUT VOLTAGE (No load)	72VDC Max.
2.3	负载范围 LOAD RANGE	9-18 个 1W LED 灯串联 9-18PCS 1W LED LAMP connected in series
2.4	效率 EFFICIENCY	≥80.3% ( 在 25°C 的环境温度下, 输入电压 230V, 负载为 18 个 1W LED 灯 ) ≥80.3% ( At 25°C ambient temperature, Input voltage 230VAC, Loading: 18pcs 1W LED lamps )
2.5	输出线 OUTPUT WIRE	UL1015 22AWG 150mm

**ATTENTION:**

如果要在驱动器次级与 LED 灯之间增加开关，需要在 LED 灯具上增加抑制浪涌电流的器件或确保浪涌电流在灯的峰值电流以内。

If you want add a switch between the secondary terminal of driver and LED lamp, the component which can suppress surge current needs to mount in the LED lamp or insure that the value of surge current is less than the peak value of the lamp.

**3. 环境要求/ ENVIRONMENTAL CONDITIONS**

3.1	ta	45°C
3.2	tc	75°C

**4. 保护特性/ PROTECTION CHARACTERISTIC**

4.1	短路保护 SHORT CIRCUIT	排除后可恢复 Resume after removed ;
4.2	过温保护 OVER TEMPERATURE	过温自动保护，降温自动恢复(采用标准 IEC 61347-1 附录 C 要求) Yes. Reset condition: Auto resume when over temperature is removed. ( The requirements of Annex C of IEC 61347-1 apply )

**5. 安全特性 / SAFETY**

5.1	耐压测试 ELECTRIC STRENGTH	输入—输出 Input-Output 输入-外壳 Input - Enclosure	3750VAC/5mA/1min ( EN61347-2-13 clause I.8.3 )
5.2	绝缘电阻 INSULATION RESISTANCE	输入—输出 Input-Output	≥4MΩ ( EN61347-2-13 clause 11 )
5.3	认证 APPROVAL		CE , SEMKO

5.4	LVD 标准 LVD STANDARD	EN61347-2-13, EN61347-1
<b>6. EMC 要求 / EMC REQUIREMENT</b>		
6.1	EMC 标准 EMC STANDARD	EN55015, EN61547, EN61000-3-2, EN61000-3-3,
<b>7. 其他信息 / OTHER INFORMATION</b>		
7.1	寿命 LIFE TIME	≥30000 hours @ 25°C with full load
7.2	外壳颜色 COVER COLOUR	白色 White
7.3	标签信息 LABEL	 <p> <b>EAGLE RISE</b>  <b>Model:ELP18X1CS</b>      Pri:220-240VAC 50/60Hz 0.13A <math>\lambda &gt; 0.9</math>      Sec:Constant Current:      DC350mA 72VDC Max.      Load:9-18W      ta:45°C tc:75°C      Intertek  <b>IP65 SELV</b> </p>
<b>8. 外形结构 / SHAPE STRUCTURE</b>		

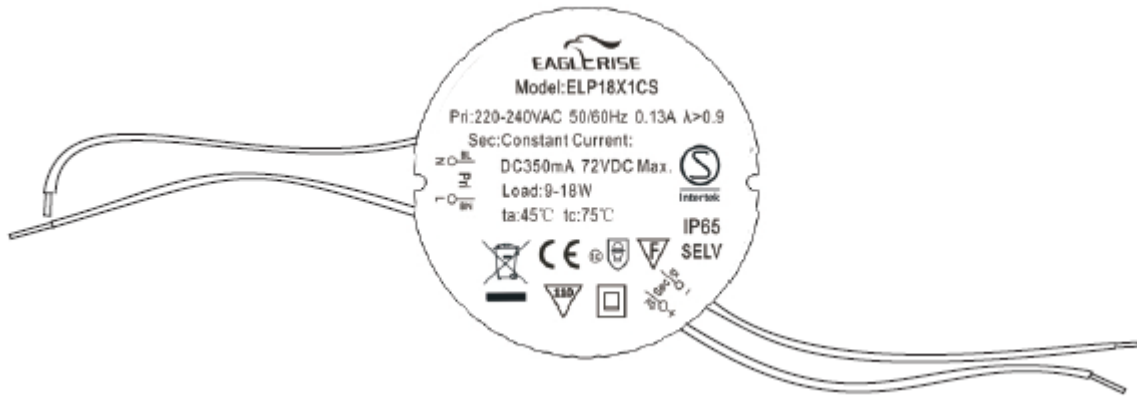
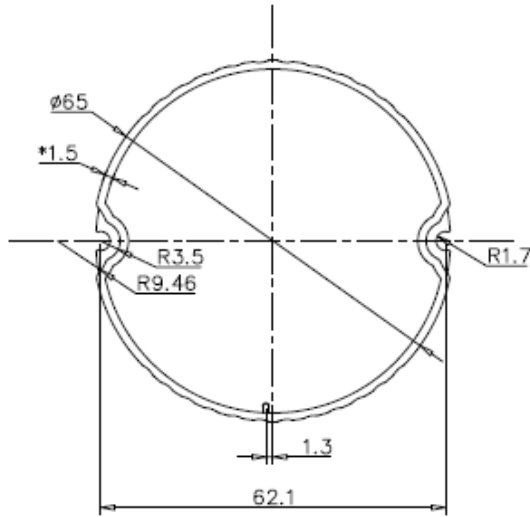
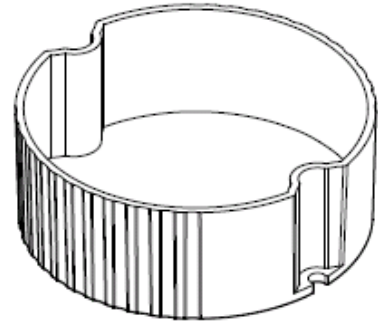
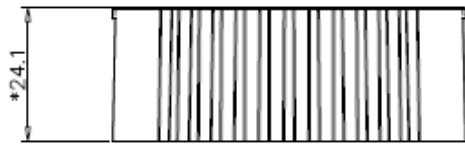

9. 变更描述 / DESCRIPTIONS OF CHANGE

变更项目 ITEM	变更前 BEFORE	变更后 AFTER	版本 Version	变更日期 DATE