



佛山市国星光电股份有限公司

FOSHAN NATIONSTAR OPTOELECTRONICS CO., LTD

产品规格书 SPECIFICATION

顾客名称 Customer		产品名称 Product	支架式发光二极管 Lamp Type LED
顾客部品号 Customer No.		产品型号 Type	BT-998BEK-31-460M-A6

顾客确认 APPROVED SIGNATURES			



地址：广东省佛山市禅城区华宝南路 18 号

Add: NO.18 South Huabao Rd,Foshan,Guangdong,China

电话 (Tel): 086-0757-83985604,83985605,83985607

传真 (Fax): 086-0757-82100221,82100223

邮编 (Zip): 528000

<http://www.nationstar.com>

研究开发中心 Research & Development Center		
批准 APPROVE	审核 CHECK	制定 DRAW
版本号 (Version NO): A1		
文件发放日期 (Release Date): 2013-12-06		

20131206998BEKA1

BT-998BEK-31-460M-A6**支架式发光二极管**

Lamp Type Emitting Diode

技术数据表 Technical Data Sheet

本产品主要作为信号指示及照明的电子元件广泛应用于各类电子产品。同时，本产品也用作室内外信息显示屏的显示单元。

This product is generally used as indicator and luminary for electronic equipment. And it also be widely used to make up variable indoor and outdoor message signal boards.

特性:**Features:**

- 5.0 mm 白色发光二极管
5.0 mm White LED Lamp
- 管芯材料: InGaN
Material:
- 无色透明封装
Water Clear Resin Package
- 功耗低, 可靠性高, 寿命长
Low Power Dissipation, Good Reliability and Long Life
- 符合欧盟公布的 RoHS 指令要求
Complied With RoHS Directive

目录**Catalogue**

电性参数	
Electrical Characteristics.....	2
外形尺寸	
Dimensions.....	3
包装	
Packaging.....	4
可靠性试验	
Reliability Test.....	5
焊接	
Soldering.....	6
使用注意事项	
Precautions.....	7

* 产品规格如因工艺改进而有所改变, 恕不另行通知。

*The Specifications of the product may be modified for improvement without notice.

◇ **极限参数 (温度=25℃):**
Absolute Maximum Ratings (Temperature=25℃):

参数名称 Parameter	符号 Symbol	最小值 Min.	最大值 Max.	单位 Unit
正向电流 Forward Current	I_F		30	mA
正向脉冲电流* Pulse Forward Current *	I_{FP}		100	mA
反向电压 Reverse Voltage	V_R		5	V
工作温度 Operating Temperature	T_{OPR}	-25	+85	℃
贮存温度 Storage Temperature	T_{stg}	-40	+100	℃
功耗 Power Dissipation	P_D		135	mW

* 注: 脉冲宽度 $\leq 0.1ms$, 占空比 $\leq 1/10$

* Note: Pulse width $\leq 0.1ms$, Duty $\leq 1/10$

◇ **光电参数 (温度=25℃):**
Electro-Optical Characteristics (Temperature=25℃):

参数名称 Parameter	符号 Symbol	条件 Condition	最小值 Min.	典型值 Typ.	最大值 Max.	单位 Unit
反向电流 Reverse Current	I_R	$V_R=5V$			50	μA
正向电压 Forward Voltage	V_F	$I_F=20mA$		3.0	4.5	V
色坐标 Chromaticity Coordinates*	X			0.30		
	Y			0.30		
光强 Luminous Intensity	I_v				1100	mcd
视角 Viewing Angle	2θ 1/2				110	(°)

*The chromaticity coordinates are derived from the CIE 1931 Chromaticity Diagram and represent the perceived color of the device.

◇ 外形尺寸 Dimension:

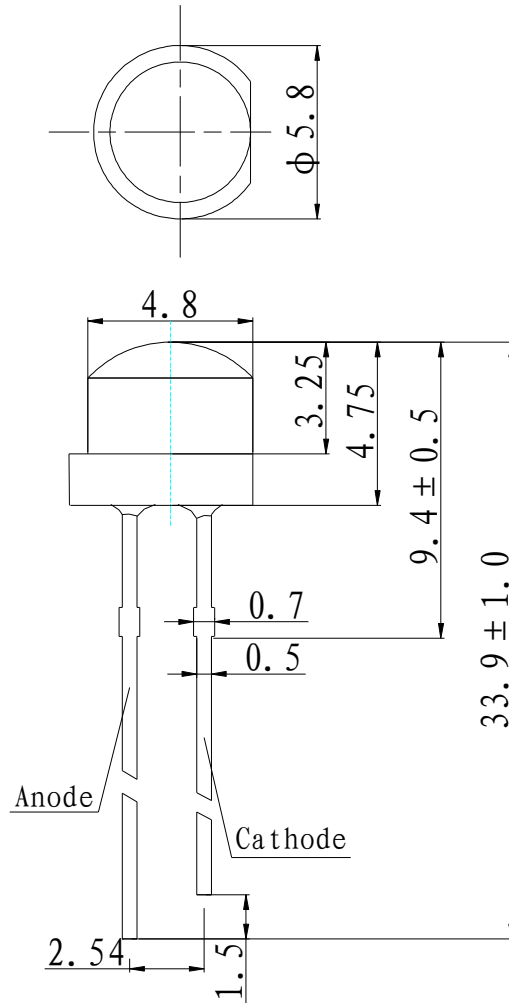

单位: mm, 未注公差: ± 0.2 mm

All dimensions in mm, tolerances unless mentioned is ± 0.2 mm.

◇ 包装 Packaging:

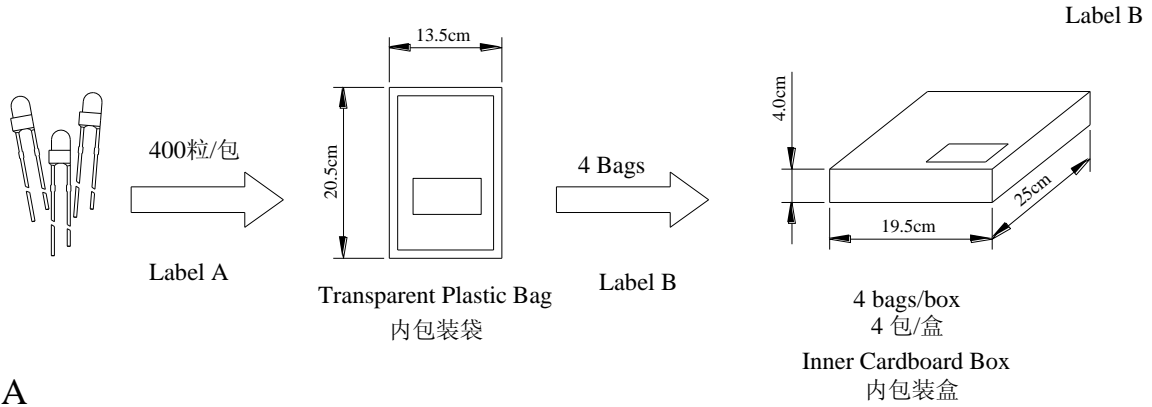

Label A

佛山市国星光电股份有限公司
 型 号: _____
 数 量: _____
 生产批次: _____
 生产日期: _____
 检 验 员: _____

Label B

佛山市国星光电股份有限公司
 型 号: _____
 数 量: _____
 生产批次: _____

Label C

佛山市国星光电股份有限公司
 型 号: _____
 生产批次: _____
 数 量: _____ pcs

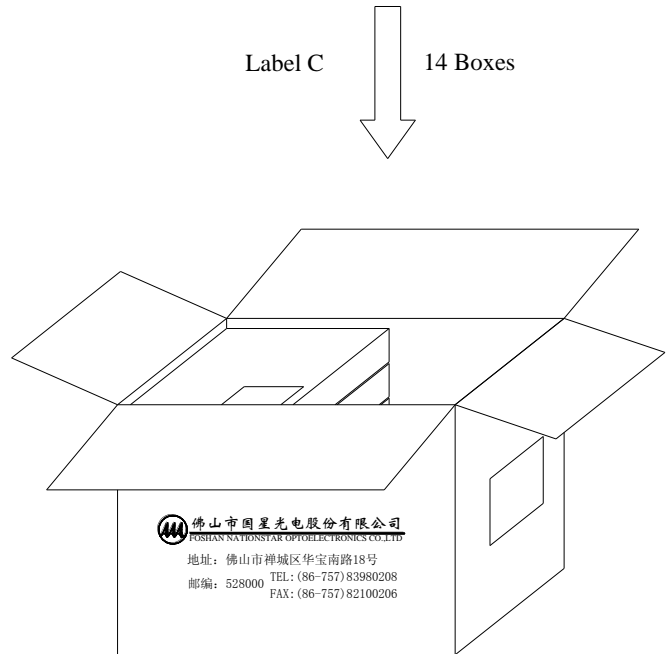

Label C

14 boxes/box
14 盒/箱
Outer Cardboard Box
外包装箱

Note: The Outer Cardboard Box is 42.0cm×27.0cm×30.0cm
外包装箱尺寸: 42.0cm×27.0cm×30.0cm

◇ 可靠性试验 Reliability Test:

试验项目 Test Items	试验条件 Test Conditions	数量 Quantity	判断标准 Judging Criteria
可焊性试验 Solderability	焊接温度 (Solder Temperature): (235±5) °C 焊接时间 (Solder Duration): 5 sec.	15	湿润良好 Good Wetting
耐焊接热试验 Resistance For Soldering Heat	(260±5) °C → 10 Sec.	15	I*
温度快速变化继之以 循环湿热 Thermal Shock Followed by High Temperature And High Humidity Cyclic	-40°C → 10 min. 5 Cycles ↓↑ Shift 转移 (2~3) min. 100°C → 10 min. ↓ 25°C~55°C (90%~95%) RH 2 次循环 48 hrs., 恢复 2 hrs. 2 Cycles for 48 hrs., Recover for 2 hrs.	20	I*
循环湿热 High Temperature And High Humidity Cyclic	25°C~55°C (90%~95%) RH 6 Cycles for 144 hrs., Recover for 2 hrs.	20	I*
电耐久性试验 DC Operating Life	1000 hrs. Forward Current: 30mA	10	I**
高温贮存试验 High Temperature Storage	100°C → 1000 hrs.	15	I**
引脚强度试验 Terminal Strength	拉伸测试 (Pull Test): 5N → 30 sec. 弯曲测试 (Bending Test): 2.5N → 2 次(2 times)	15	无损坏 No Noticeable Damaged

***1 失效判断标准 Criteria For Judging Damage**

测试项目 Items	符号 Symbol	测试条件 Test Conditions	失效判断标准 I* Criteria For Judging Damage I*	失效判断标准 I** Criteria For Judging Damage I**
正向电压 Forward Voltage	V _F	I _F =20mA	≤USL	≤USL×1.2
反向电流 Reverse Current	I _R	V _R =5V	≤USL	≤USL×2.0
光强 Luminous Intensity	I _V	I _F =20mA	≥LSL	≥IL×0.5

* USL: 标准值上限值, LSL: 标准值下限值, IL: 初始值

* USL: Upper Standard Level, LSL: Lower Standard Level, IL: Initial Level

◇ 焊接 Soldering

焊接过程中的不慎操作将会引起产品的损坏，请务必注意。焊接过程中应避免对产品支架或封装部分施加压力。焊接时，请保证焊接位置与封装树脂底部有一定的距离，该距离因不同的焊接方法而有所不同，请参照以下推荐焊接条件。

Be careful because damages always caused during soldering. Please note that stress to the Leads and expose bulb should be avoided during soldering particularly when heated. When soldering, leave certain distance from soldering joint to base, the distance is determined by different soldering techniques. It is recommended that soldering be performed base on the following conditions.

* 推荐焊接条件 Recommended Soldering Conditions:

槽焊/波峰焊接 DIP Soldering		烙铁焊接 Hand Soldering	
预热 Pre-Heat	100 °C Max., 60 sec. Max.	焊接温度 Temperature	300 °C Max.
浸润温度 Bath Temperature	260 °C Max.		
浸泡温度 Dipping Time	5 sec. Max.	焊接时间 Soldering Time	3 sec. Max.
浸泡位置 Dipping Position	2 mm Min. (与树脂底部的距离) (from soldering joint to base)	焊接位置 Soldering Position	4 mm Min. (与树脂底部的距离) (from soldering joint to base)

- 不管采用何种焊接方法，焊接只能进行一次。

Either DIP Soldering or Hand Soldering should not be done more than one time.

- 焊接完成后，在 LED 温度下降到室温之前，请不要对产品施加压力。

After soldering, the LEDs should be protected from mechanical shock or stress before the LEDs cool down to room temperature.

- 在 LED 温度降回室温后，再进行切除引脚多余部分的操作。

Cut the leadframes after the LEDs return to room temperature.

- 建议使用酒精作为清洗溶液对焊接完成品进行清洗。使用其他类似溶剂清洗之前，请确认使用的溶剂不会对 LED 造成损伤。

It is recommended that alcohol be used as a solvent for cleaning after soldering. When using other solvents, or other cleaning method it should be confirmed beforehand whether the solvents will dissolve the resin or not.

注意：此一般指导原则并不适用于所有 PCB 设计和焊接设备的配置。具体工艺受到诸多因素的影响，请根据特定的 PCB 设计和焊接设备来确定焊接方案。

Note: This general guideline may not apply to all PCB designs and configurations of all soldering equipment. The techniques in practice is influenced by many factors, it should be specialized base on the PCB designs and configurations of the soldering equipment.

◇ 使用注意事项 Precautions

1. 贮存

Storage

在温度低于 30℃，湿度不高于 70%RH 的条件下，产品保存期限为 6 个月。将产品保存在密封的容器中并附带干燥剂可以在一定程度上延长产品的贮存日期。不良的贮存条件会导致产品引脚的腐蚀或产品性能的改变。

Under the storage conditions of 30℃ or less and humidity less than 70% RH, the LEDs can be storage for 3 months. Storage in a sealed container with moisture absorbent material can prolong the storage time to a certain extent. Bad storage conditions may cause the leadframes to corrode or degradation of LED characteristics. It is recommended that the LEDs be used as soon as possible.

2. 静电

Static electricity

静电和电涌会导致产品特性发生改变，例如正向电压降低等，如果情况严重甚至会损毁产品。所以在使用时必须采取有效的防静电措施。

所有相关的设备和机器都应该正确接地，同时必须采取其他防止静电和电涌的措施。使用防静电手环，防静电垫子，防静电工作服、工作鞋、手套，防静电容器，都是有效的防止静电和电涌的措施。

Static electricity or surge voltage damages the LEDs. Damaged LEDs will show some unusual chrematistics such as the forward voltage becomes lower, or the LEDs do not light at the low current, even not light.

All devices, equipment and machinery must be properly grounded. At the same time, it is recommended that wrist bands or anti-electrostatic gloves, anti-electrostatic containers be used when dealing with the LEDs.

3. 设计建议

Design Consideration

设计电路时，通过 LED 的电流不能超过规定的最大值，同时，还需使用保护电阻，否则，微小的电压变化将会引起较大的电流变化，可能导致产品损毁。

LED 的特性容易因为自身的发热和环境的温度的改变而发生改变。温度的升高会降低 LED 的发光效率、影响发光颜色等，所以在设计时应充分考虑散热的问题。

When designing a circuit, the current through each LED must not exceed the absolute maximum rating specified for each LED. In the meanwhile, resistors for protection should be applied, otherwise slight voltage shift will cause big current change, burn out may happen.

Thermal Design is paramount importance because heat generation may result in the Characteristics decline, such as brightness decreased, Color changed and so on. Please consider the heat generation of the LEDs when making the system design.

4. 支架整形

Lead Forming

支架的整形必须在焊接之前进行。整形时，支架的弯曲位置必须至少在封装树脂底部 3mm 处，同时，避免对同一个位置进行多次的弯曲。

整形时，请使用合适的工具固定支架，避免对树脂施加压力。特别是不能将管脚与树脂的连接部分作为支点，这样产生的应力会直接对产品内部的发光结构造成损伤，导致产品特性的改变甚至损毁。

基于同样的原因，在装配产品的时候，PCB 板上焊孔间的距离必须于产品的管脚间距严格匹配，

Any lead forming must be done before soldering, not during or after soldering. When forming leads, the leads should be bent at a point at least 3mm from the base of the expose bulb. Bending at the same point twice or even more should be avoided.

Please use proper tools to hold and bent the leads, do not use the base of the leadframe as a fulcrum during lead forming. Bending stress to the base of the leadframe may cause characteristics change on LED or even break it.

Just for the same reason, when mounting the LEDs onto a printed circuit board, the holes on the circuit board should be exactly aligned with the leads of the LEDs.

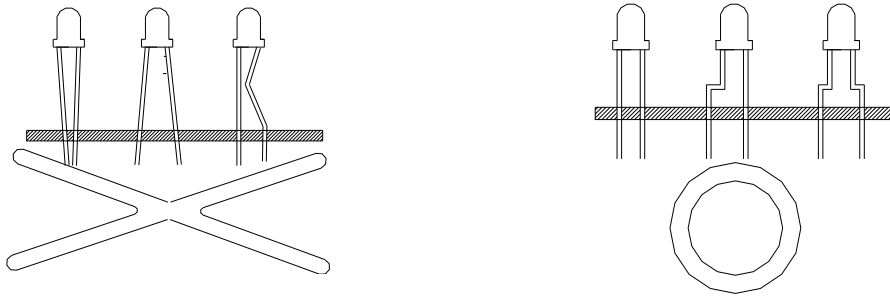

5. 眼睛保护忠告：

Safety Advice for Human Eyes

LED 发光时，请勿直视发光光源，特别是对于一些光强较高的 LED，强光可能伤害你的眼睛。

Viewing direct to the light emitting center of the LEDs, especial those of great Luminous Intensity, will cause great hazard to human eyes. Please be careful.



佛山市国星光电股份有限公司
FOSHAN NATIONSTAR OPTOELECTRONICS CO., LTD

地址：佛山市禅城区华宝南路 18 号

电话 (Tel): (0757) 83985604, 83985605, 83985607

Add: NO.18 South Huabao Rd, Foshan, Guangdong China

传真 (Fax): (0757) 82100221, 82100223

邮编 (Zip): 528000

<http://www.nationstar.com>