

Product Specification

Number: L-KLS5-102-5RT-010H-R

Name: Micro Fuses

Customer: _____

Date: 2025-02-24

Customer Signature:



WWW.KLSELE.COM

NINGBO KLS ELECTRONIC CO; LTD

Tel : 0086-574-86828566

Fax : 0086-574-86824882

**ADD : NO. 8-1, RONGXIA RD. XIAPU SHANQIAN
INDUSTRIAL ZONE BEILUN NINGBO ZHEJIANG.**

Compi	Check	Review	Approva
Jenny	Jack.C		

Part name	Micro Fuses	Date	2025-02-24
Part number	L-KLS5-102-5RT-010H-R	Edition	V1
Department		Page	2 / 10

目 录

1	承认书封面 Approval sheet cover.....	1
2	承认书目录 Catalogue of approval sheet.....	2
3	变更记录表 Change Record.....	3
4	技术要求 Technique request	4
1	适用范围 Available range.....	4
2	型号定义解释 Model meaning	4
3	相关标准 Safety Standards.....	4
4	尺寸、结构、外观 Size、structure、appearance.....	4-6
5	电气特性 Electrical performance.....	6-8
6	安装方式及条件 Installation Way and Parameters.....	9
7	环境特性 Environmental characteristic.....	9
8	信赖性试验 Reliability test.....	10
9	产品标志 Marking.....	10
10	包装 Packing.....	11
11	料号解释 Part No description.....	11
12	样品测试报告 Sample test Report.....	12
13	认证和环保 Certification and RoHS.....	13-27

Part name	Micro Fuses	Date	2025-02-24
Part number	L-KLS5-102-5RT-010H-R	Edition	V1
Department		Page	3 / 10

变更记录表

Change Record

序号 NO.	日期 Date	修改内容 Change Description	版本 REV.
1	2018-05-25	新版发行/New version	1.0
2			
3			
4			
5			
6			
7			
8			
9			
10			

Part name	Micro Fuses	Date	2025-02-24
Part number	L-KLS5-102-5RT-010H-R	Edition	V1
Department		Page	4 / 10

产品规格书

Sub-miniature fuse-link Specification

1. 适用范围 (Available range) :

本保险丝适用于保护家用电器, 电子仪器, 电源供应器、显示器等。

For protecting instruments, power supply devices and telephone sets etc.

2. 型号定义解释 (Model meaning):

(5RT: Slow Blow Fuses)

3. 相关标准 (Safety Standards) : GB9364 IEC60127

4. 结构尺寸 (Size and Structure)

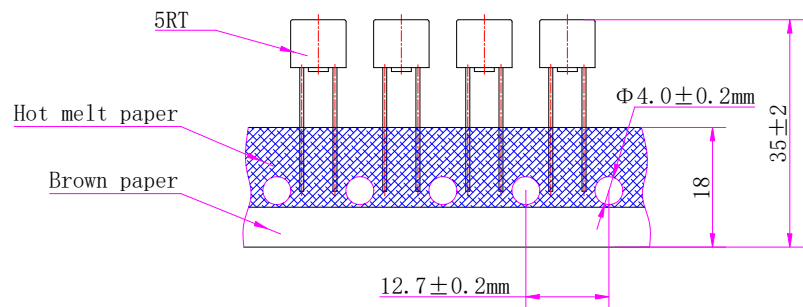
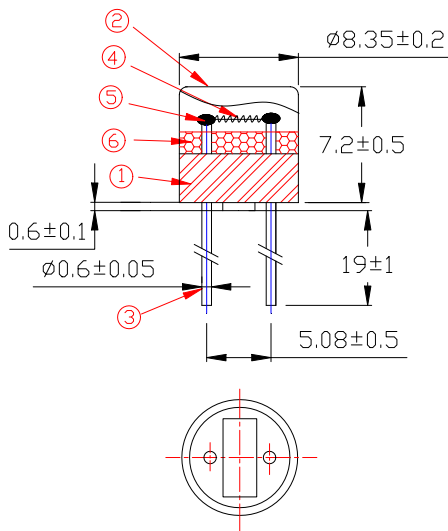

Part name	Micro Fuses	Date	2025-02-24
Part number	L-KLS5-102-5RT-010H-R	Edition	V1
Department		Page	5 / 10

编号 No.	部件 Part Name	材料 Material	备注 Remarks
①	内芯 Base	塑料 Plastic	
②	外壳 Cap	塑料 Plastic	
③	引脚 Lead Wire	镀锡铜线 Tin Plated Copper	
④	熔丝 Fuse Element	合金 Alloy	
⑤	焊锡 Solder	锡线 (Sn99.3%Cu0.7%) Solder wire(Sn99.3%Cu0.7%)	RoHS
⑥	砂 Filler	二氧化硅 SiO ₂	

4.1 型号及标示 (Model and indication)

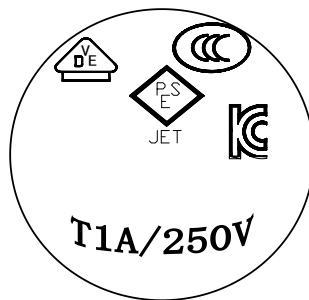

型号 Model	额定电压/电流 Rated Voltage/Current	商标. 品名. 认证 Trademark. Type. Approved mark
L-KLS5-102-5RT	T1A/250V	

Part name	Micro Fuses	Date	2025-02-24
Part number	L-KLS5-102-5RT-010H-R	Edition	V1
Department		Page	6 / 10

4.3 外壳 (Cap)

外壳无破裂、缺损、脏污等现象。

The cap shall have no defects such as crack, injury and contamination.

4.4 引脚 (Lead Wire)

保险管引脚应固定牢固，作如下测试时，保险管引脚不应有松动或损坏：

The fuse-links lead should be firmly attached, At the conclusion of testing, the fuse-links lead shall remain firmly attached:

1) 拉力测试：固定保险管本体，对引脚施加 10N 的轴向拉力 1min。

Tensile: the force applied shall be 10N

2) 推力测试：固定保险管本体，对引脚施加 2N 的轴向推力 1min。

Thrust: the force applied shall be 2N

3) 弯折测试：距离内芯约 2mm 的地方将引脚弯折 90° 一次，并且施加 5N 的拉力。

Bending: the force applied shall be 5N and the number of bends shall be one.

4.5 外观 (Appearances)

1) 外壳不能有破裂。

There shall no fragmentation.

2) 不能有明显脏污。

Any of remarkable blotch.

3) 标识清晰。

Illegibility of marking.

5. 电气特性 (Electrical performance)

5.1 测试条件 (Testing Ambient)

测试条件都应在下列大气条件下进行：

All tests should be carried out under the following conditions:

-温度 (Surrounding temperature): 15°C~35°C;

-相对湿度 (Relative humidity): 45%~75%;

-大气压力 (Atmosphere pressure): 8.6×10^4 Pa~ 1.06×10^5

Part name	Micro Fuses	Date	2025-02-24
Part number	L-KLS5-102-5RT-010H-R	Edition	V1
Department		Page	7 / 10

5.2 预飞弧/时间电流特性 (Time-current Characteristic)

电流 (In ratio) 型号类别 (Item NO.)	150%	210%	275%	400%	1000%
5RT Series	>1h	<120s	≥400ms ≤10s	≥150ms ≤3s	≥20ms ≤150ms
1A I ² t 平均参考值	7.2A ² S±20%				

5.3 分断能力 (Breaking capacity)

1) 100A @250V AC 分断电流测试。

Breaking capacity test: 100A @250V AC

2) 每一次测试, 保险管能安全动作, 不能出现以下现象:

In each of the tests, the fuse-link shall operate satisfactorily without any of the following phenomena:

- 持续电弧;
- permanent arcing;
- 引燃;
- ignition;
- 保险管爆炸;
- Bursting of the fuse-link.

注意: 颜色改变不认为是不合格.

NOTE: changes in color are not considered as a failure.

型号 Model	额定电流 Rated Current	安全认证分断电流 Safe attestation Breaking current
		
L-KLS5-102-5RT	所有	100A @250V AC

Part name	Micro Fuses	Date	2025-02-24
Part number	L-KLS5-102-5RT-010H-R	Edition	V1
Department		Page	8 / 10

5.4 时间电流特性曲线图 (Time-current curves)

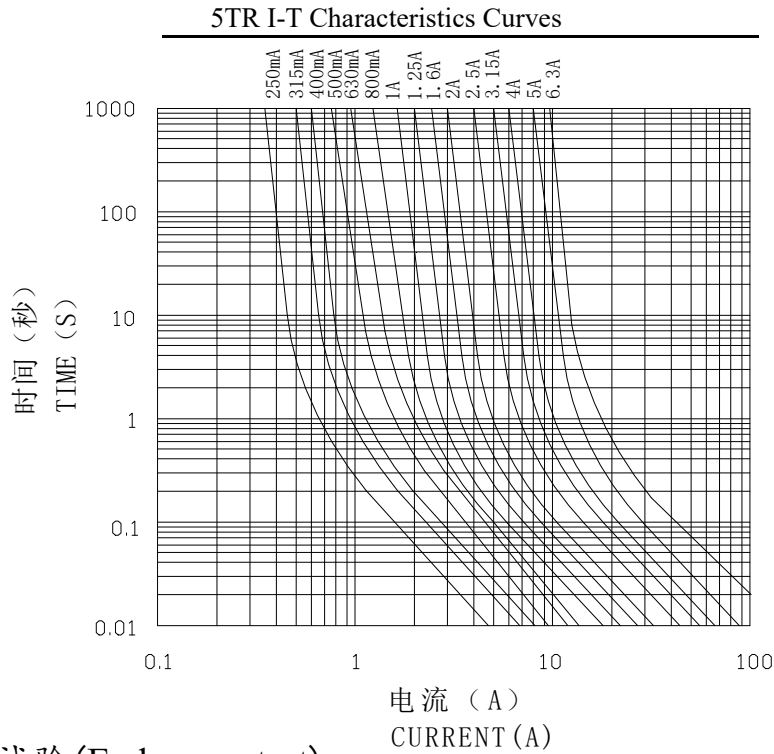

5.5 耐久性试验 (Endurance test)

1) 对保险丝通过 1 倍额定电流 1 小时，然后切断 15 分钟，重复此循环 100 次。

A current $1 I_n$ is passed through the fuse-link for a period of 1h. The current is then switched off for a period of 15 min. The cycle is repeated 100 times.

2) 然后对熔断体通以 1.5 倍额定电流 1 小时。

A current $1.5 I_n$ is then passed through the fuse-link for 1h.

3) 测量熔断体两端的电压降，试验后，熔断体两端的电压降的增大量不大于试验前测得值的 10%。

Finally, the voltage drop across the fuse-link is measured. The voltage drop across the fuse-link after the test shall not have increased by more than 10% of the value measured before the test.

4) 试验后，标记仍应清晰可辨，而且诸如端帽上的焊点不应出现任何明显的劣变。

After the test, the marking shall still be legible and soldered joints on end caps, for example, shall not show any appreciable deterioration.

Part name	Micro Fuses	Date	2025-02-24
Part number	L-KLS5-102-5RT-010H-R	Edition	V1
Department		Page	9 / 10

6. 安装方式及条件 Installation Way and Parameters

6.1 建议如下图安装方式安装

Propose that the following picture installation way is installed

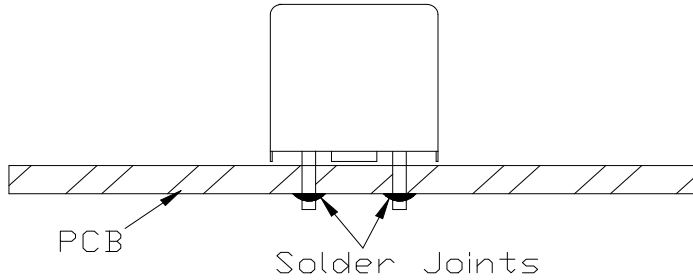

6.2 环保焊接条件 Soldering conditions (RoHS)

波峰焊/Wave solder: 260°C, ≤5S

手工焊/Hand solder: 360°C, ≤1S

7. 环境特性 Environmental characteristic

7.1 温度-电流负荷比曲线 Temperature-Current Curve

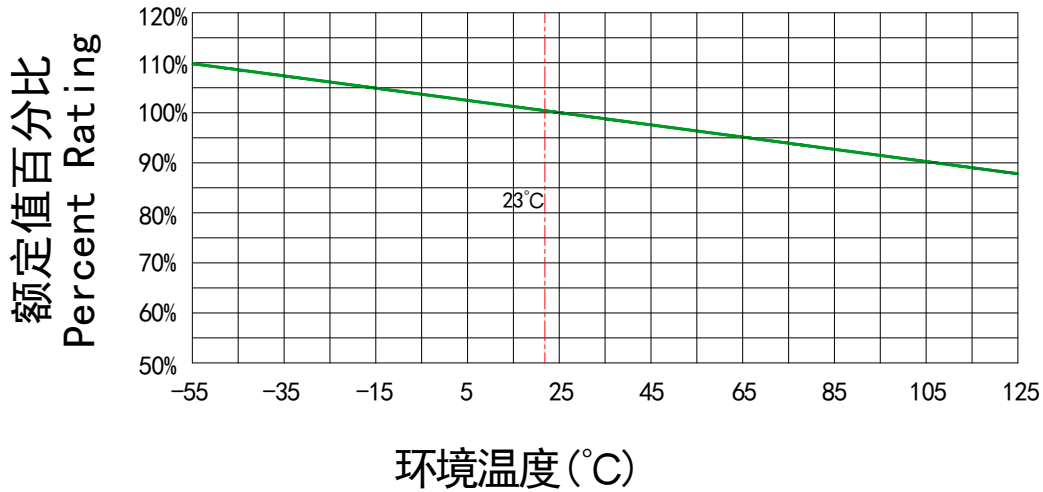

Ambient Temperature (°C)

7.2 工作温度/Operating temperature : -55°C~125°C

7.3 贮存条件 Storage conditions

贮存温度/Storage temperature: 5°C~35°C

贮存湿度/Storage humidity: 25%~85%

贮存周期/Storage time: 6 months

Part name	Micro Fuses	Date	2025-02-24
Part number	L-KLS5-102-5RT-010H-R	Edition	V1
Department		Page	10 / 10

8. 信赖性试验 (Reliability test)

项目/Item	试验要求/Test Requirement	试验条件/Test Condition
高低温试验 High & low Temperature Test	试验后保险丝管的电阻符合范围 After test, the resistance value of the fuses shall be in range	测试高温: 85°C, 测试时间: 48h Test high temperature: 85°C, Test time: 48h; 测试低温: -20°C, 测试时间: 48h Test low temperature: -20°C, Test time 48h
高湿试验 High Humidity Test	试验后保险丝管的电阻符合范围 After test, the resistance value of the fuses shall be in range	测试温度: 85°C, 测试湿度: 95%. 测试时间: 96h Test temperature: 85°C, Test humidity: 95% Test time: 96h
落下、冲击试验 Falling Shock Test	外壳应固定牢固, 以保证在未损坏熔断体时, 外壳不能被卸下, 引线应能经受专用的设备外加轴向拉力 5N, 保持 1 分钟, 保险管必须无缺陷破裂和缺损, 试验后保险丝管的电阻符合范围。 Cap should be firmly attached so that it is not possible to remove them without damaging the fuse itself. The means of attachment shall be sufficient to withstand an axial pull of 5N applied to Lead wire for 1 minute. The fuse shall have no defects such as crack and injury .After falling shock test, the resistance value of the fuses shall be range.	保险管从 152cm 高度自由落下, 跌落 5 次。 Falling Height: 152cm Falling Times: 5
振动试验 Vibration	试验后保险丝管的电阻符合范围 After test, the resistance value of the fuses shall be in range	振幅 1.5mm, 频率 10~55~10HZ, 时间 2 小时 Amplitude: 1.5mm, Frequency: 10 ~ 55 ~ 10HZ, Test time ; 2h

9. 标志 (Marking)

- 1) 额定电流 (Rated current) : 1A
- 2) 额定电压 (Rated voltage) : 250V
- 3) 型号 (Model) : 5RT