



SPECIFICATION

PN: KSE-6K632768KDY240ZA3

Crystal Resonators

JU206/308 KHZ 6K6 Series

FEATURE

- Best suited for portable devices with low current consumption.
- For a clock source in digital equipments.
- RoHS Compliant / Pb Free.

ELECTRICAL SPECIFICATIONS

Frequency range	32.768KHz
Package	2x6mm
Frequency Tolerance (at 25°C)	±20ppm
ESR	50KΩ Max
Turnover Temperature	25 ± 5°C
Frequency Temperature Curve	[-0.035±0.01]ppm/°C ²
Operable Temperature Range	-40°C to +85 °C
Storage Temperature Range	-40 °C to +85 °C
Shunt Capacitance (C0)	1.75pF Typical
Dynamic Capacitance (C1)	0.0035fF Typical
Driver Level (DL)	1 μW Typical
Capacitance Ratio C0/C1	500 Typical
Quality Factor Q	60000Typical
Load Capacitance(CL)	12.5PF
Insulation Resistance	500Mohm Min DC=100V± 15V(Pin to Pin,Pin to case)
Aging @25°C 5st year (Max)	±3ppm/year

Crystal Resonators

JU206/308 KHZ 6K6 Series

DIMENSION (Unit: mm)

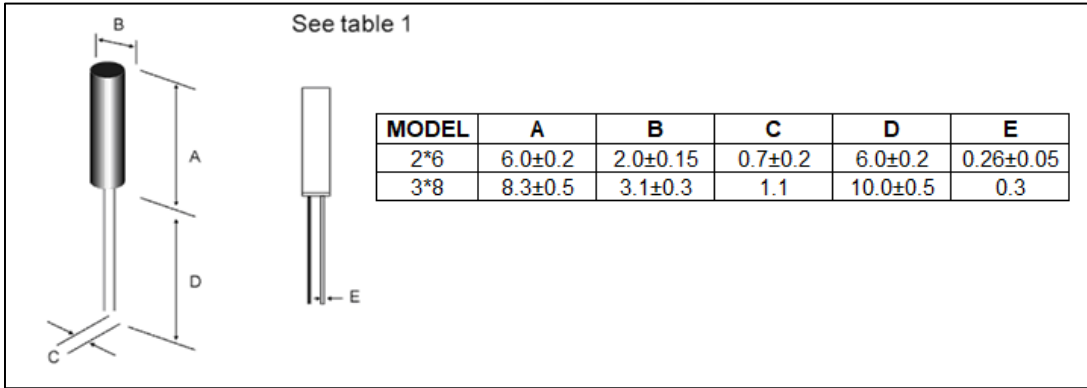

MARK

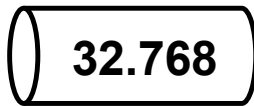

Frequency VS Temperature Curve

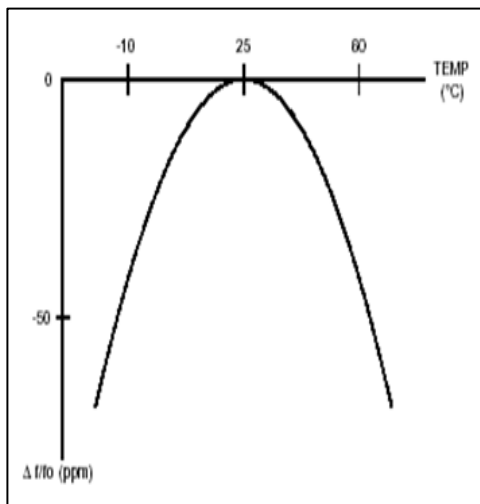

Oscillation Circuit

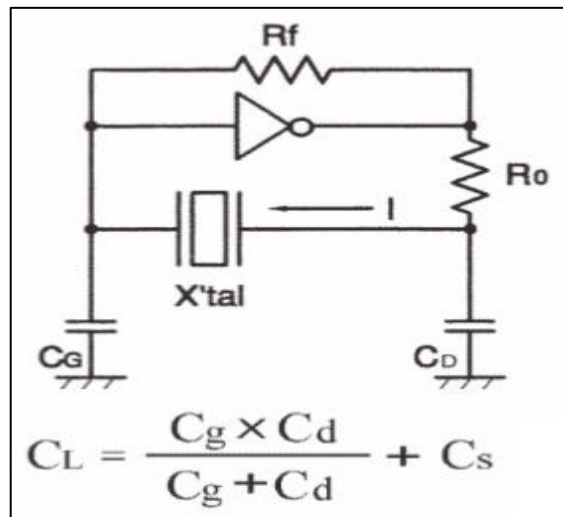

Crystal Resonators

JU206/308 KHZ 6K6 Series

Environment-proof . Mechanical property

No	Item	Specifications	Conditions	
1	High temperature storage	$\Delta f/f = \pm 5 \times 10^{-6}$	After storage under 85°C for 500 hrs, measure at room temperature.	1
2	Low temperature storage	$\Delta f/f = \pm 5 \times 10^{-6}$	After storage under -40°C for 500hrs, measure at room temperature	1
3	High temperature and high humidity storage	$\Delta f/f = \pm 5 \times 10^{-6}$	After storage under 60°C±2°C, 90 to95% RH for 500 hrs, measure at room temperature .	1
4	Thermal shock resistance	$\Delta f/f = \pm 5 \times 10^{-6}$	Measured at room temperature after20 cycles. -25°C ↔+80°C for 30 minutes.	1
5	Mechanical shock resistance	$\Delta f/f = \pm 5 \times 10^{-6}$	Measure after free drop of the RESONATOR three times from the height of 75cm onto a wooden board.	2
6	Vibration resistance	$\Delta f/f = \pm 5 \times 10^{-6}$	Amplitude 1.5mm and 10 ~ 60Hz with cycle time 2 ~ 3 minutes in 3 direction (X,Y,and Z axis)each for 2 hrs.	2
7	Resistance to soldering heat	$\Delta f/f = \pm 5 \times 10^{-6}$	Measured at room temperature after immersing the lead wire in a soldering bath of 300°C±10°C for 5 seconds up to a position where it is2mm away from the root of the plug.	1
8	Tensile strength of lead wire	$\Delta f/f = \pm 5 \times 10^{-6}$	Apply a load of 500g for 30 seconds in the lead wire's axial direction.	2
9	Bending strength of lead wire	$\Delta f/f = \pm 5 \times 10^{-6}$	Bending cycle : 0 ° → 45 ° → 0 ° → 45 ° → 0 °	2
10	Solderability of lead wire	A minimum 95% of the area to be coated with solder	Apply resin-flux contained-solder to a soldering iron of 280°C±5°C for 5 seconds.	2

Note:

1. The above tests no. 1 to 9 must be conducted independently (not series tests)
2. *1: Measure after 24 hours soak at room temperature .
3. *2: Measure after 2 hours soak at room temperature .

Precautions

- (1) Temperature for soldering the lead wire shall not exceed 300°C and the soldering time shall be within 5 seconds.
- (2) Position to be soldered : Solder only the position where the lead wire is1.0mm away from the glass seal. Do not solder the case.
- (3) Cutting, bending and correction of lead wire: The glass seal shall be free of any crack or other damage which may deteriorate the characteristics of RESONATORS.

REVISION RECORD (KSE-6K632768KDY240ZA3)

Rev	Revise contents	Reason	Reviser	Checked	Approved
A1	Initial released	--			