

**NOTES:**

1. Rating:300V 15A;
2. Insulation Withstands Voltage: AC2000V/MIN
3. Insulation Resistance:  
500MΩ or more at DC500V
4. Using Temperature Range: -40° C~+105° C
5. Screw Torque Vlaue:0. 4N.m
6. Suitable Electric Wire: 28~12AWG
7. " ★ " is the important dimension.
8. Material:①Housing: PA66 (UL94-V0);  
②Cover: PA66 (UL94-V0);  
③Clamp: C5191, Ni plated;  
④Screw: Steel, Zinc plated;  
⑤Block: Copper, Ni plated;

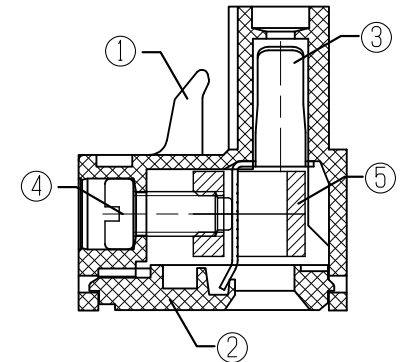
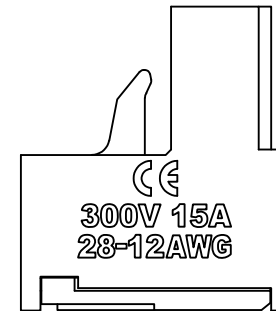
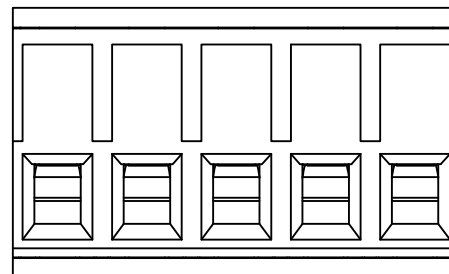
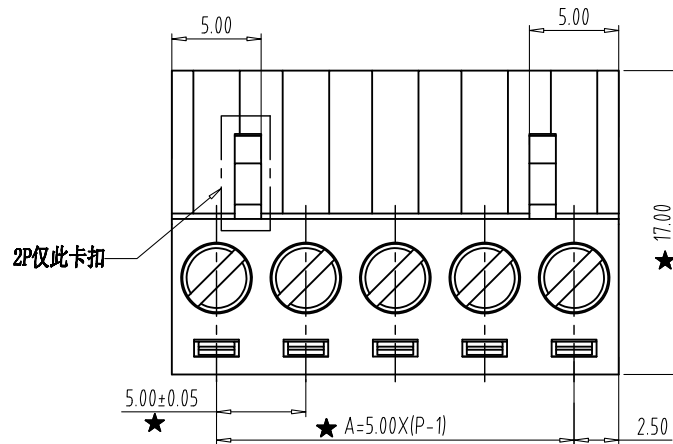
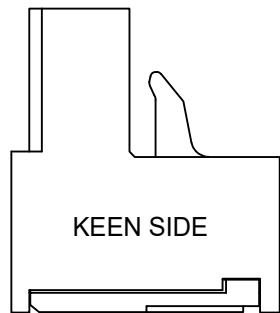
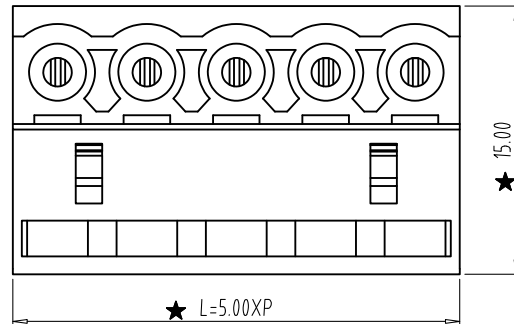

**KSE - 2EDGK - 5.00 - XXP - (T) - (S)**

Slot screw  
Block: steel, Zn plated

Total Pitch Tolerances in mm										Nominal dimension range in mm										⊥	≡	-	//								
over 0	over 30	over 53	over 70	over 90	over 115	over 150	over 250	over 350	over 500	over 0	over 30	over 53	over 70	over 90	over 115	over 150	over 200	over 250	over 320	over 0	over 10	all	over 0	over 100	over 150	0.2	0.3	0.3	0.2	0.3	0.5
±0.18	±0.20	±0.25	±0.3	±0.35	±0.44	±0.60	±0.70	±0.85	±0.20	±0.25	±0.30	±0.35	±0.44	±0.55	±0.70	±0.80	±0.90	0.2	0.3	0.3	0.2	0.3	0.5								

ITEM	NAME OF PART	NO. OF PART	Q'TY	MATERIAL	NOTE
DWG.	DATE	2014-12-05	SIZE	A4 UNITS mm	SHEET/OF 1 / 1
CHK.	DATE		SCALE	2.5:1	
APP.	DATE				
				NAME KSE-2EDGK-5.00-XXP	
				DWGNO.	