

GNL-8003xx (Φ 8mm ROUND TYPE) Ultra Brightness

ABSOLUTE MAXIMUM RATING:(Ta=25°C)

Parameter			Unit
DC Forward Current	30		mA
Reverse Voltage	5		V
Reverse Current (Vr=5V)	10		μA
Peak Forward Current ,tw ,=1 msec Duty ,=1/20	150		mA
Operation Temperature	-40	+80	°C
Storage Temperature	-40	+100	°C
Solder Dip (5 seconds,1.6mm from body) Temperature	300	±5	°C

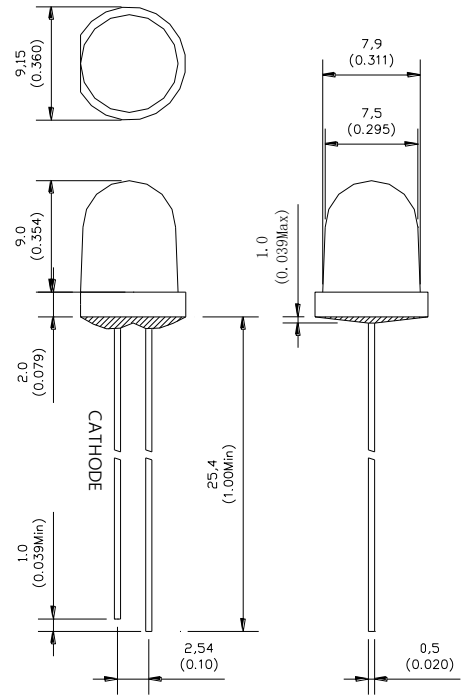

Feature:

- 1.Small flange without stand-off
- 2.Long life-solid state reliability
- 3.Long lead length(25.4mm)
- 4.Versatile mounting on P.C. board or panel

Description:

- 1.The shape of this series is round
- 2.General application is for indication,illumination,etc.
- 3.These LED lamps are available with a choice of defferent colors,light intensities,epoxy colors,etc.

Part Number	EMITTED COLOR		Lens Color	Peak Wavelength (nm)	Vf (v) Typ.	IV (If=20mA) mcd		View Angle 2 θ 1/2
						Min.	Typ.	
GNL-8003SRD	GaAlAs	Super Red	Red Diffused	660	1.9	50	100	60°
GNL-8003LRD	GaAlAs	Super Red	Red Diffused	660	1.9	200	400	60°
GNL-8003SRT	GaAlAs	Super Red	Red Transparent	660	1.9	250	400	22°
GNL-8003SRC	GaAlAs	Super Red	Water Clear	660	1.9	250	400	22°
GNL-8003LRC	GaAlAs	Super Red	Water Clear	660	1.9	600	800	22°
GNL-8003URC	GaAlAs	Super Red	Water Clear	660	1.9	1200	1500	22°
GNL-8003UEC	AlGaInP	Super Orange Red	Water Clear	625	2.0	1500	2000	22°
GNL-8003HRC	AlGaInP	Super Orange Red	Water Clear	640	2.0	1200	1800	22°
GNL-8003UEC-TL	AlGaInP	Super Orange Red	Water Clear	625	2.0	4000	5000	22°
GNL-8003UYC	AlGaInP	Super amber	Water Clear	585	2.0	1500	2000	22°
GNL-8003UYC-TL	AlGaInP	Super amber	Water Clear	585	2.0	4000	5000	22°
GNL-8003UBC	InGaN	Ultra Super Blue	Water Clear	470	3.5	1800	3500	22°
GNL-8003UBC-TL	InGaN	Ultra Super Blue	Water Clear	470	3.5	2500	4500	22°
GNL-8003UBD-TL	InGaN	Ultra Super Blue	Blue Diffused	470	3.5	1000	1500	60°
GNL-8003BC-1	InGaN	Super Blue	Water Clear	470	3.5	1500	2000	22°
GNL-8003PGC	InGaN	Super Pure Green	Water Clear	525	3.5	5000	9000	22°
GNL-8003PGC-TL	InGaN	Super Pure Green	Water Clear	525	3.5	8000	12000	22°
GNL-8003UWC	InGaN	Ultra Super White	Water Clear	5500K-7000K	3.5	4000	9000	22°
GNL-8003VC	InGaN	Super Violet	Water Clear	400	3.5	100	300	22°

